

Tool Grinding Machine

 REINECKER

WZS 8

Discipline: Freestyle



WZS 8 REINECKER

Anything is possible - for individual applications

Wide range of applications for manufacturing and resharpening simple and complex tools up to 32 mm in diameter with low space requirements.

Good to know

- **Reliable results:**
Machine bed made of polymer concrete for optimum vibration damping, excellent rigidity, thermal stability and efficient swarf removal.
- **Maximum precision:**
Measuring systems with high resolution close to the grinding point. Direct drive in the linear axes X and Z.
- **High performance level:**
Grinding spindle with synchronous technology and rotary axes with liquid-cooled direct drives.
- **Variable clamping systems for workpieces:**
Collet chuck, hydraulic chuck or multi-range chuck.
- **Optimized processes:**
8-station grinding wheel magazine and different solutions for workpiece automation.
- **Ergonomics for maintenance and service:**
Easy and quick maintenance and repair thanks to good accessibility to service-relevant areas.
- **Modern security:**
Operating mode selector switch with RFID-coded recognition of users and their authorizations and integrated NUM-Safe security architecture.
- **User-friendly application:**
Control panel with 24" multi-touch screen as well as NUMROTOplus® programming system and collision detection.
- **Innovative design:**
Integrated operating status light with long-distance effect in the front area for quick recognition of operating statuses.
- **NUM FlexiumPro:**
CNC control with powerful NUM DrivePro drives and integrated NUM-SAMX unit for monitoring safety-related movements.
- **User interface**
REINECKER CONTROL:
Central control and information platform for the operator.

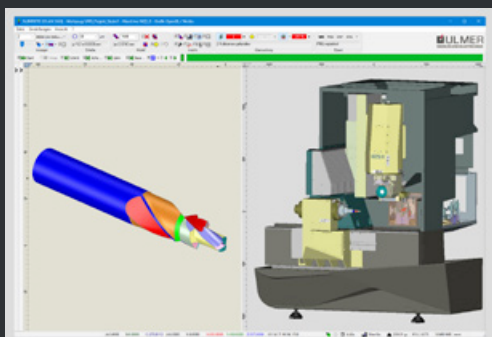

NUMROTOplus®
Programming system
with 3D graphics



REINECKER
CONTROL

Applications & Equipment

Our "Freestyler" is the perfect solution for production of smaller workpieces and resharpening of quality tools.

Variable clamping systems

A wide range of industry standard clamping systems for workpieces are available.

Support

Steady rest for stabilizing slender workpieces.
Clamping device optional.

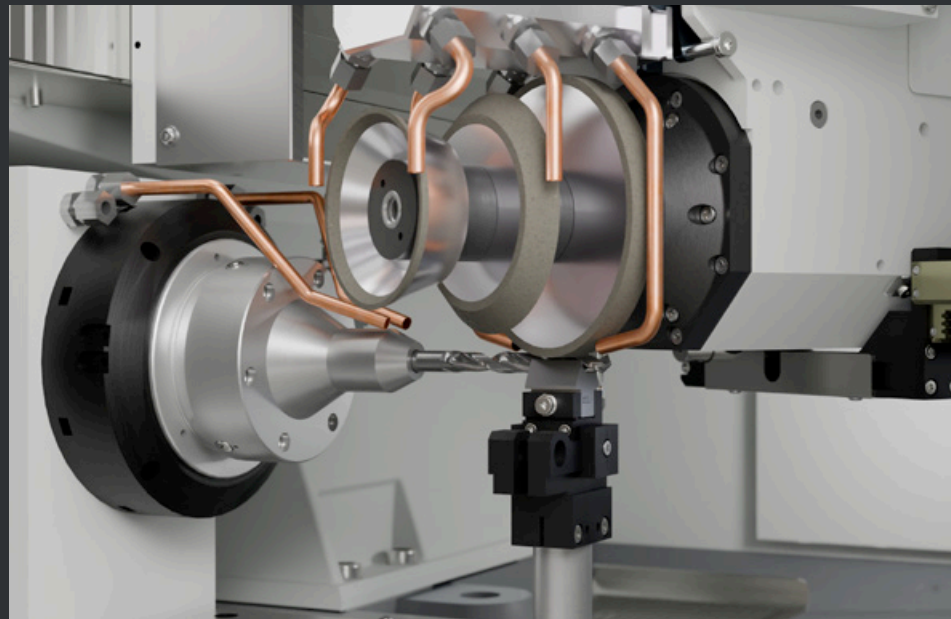

Shank Steady Rest

Maximum concentricity for tools with shank diameters from 2 mm to 6 mm [0.08 - 0.24"].

Second Probe

Process-related measurement of the grinding wheels in the machine.

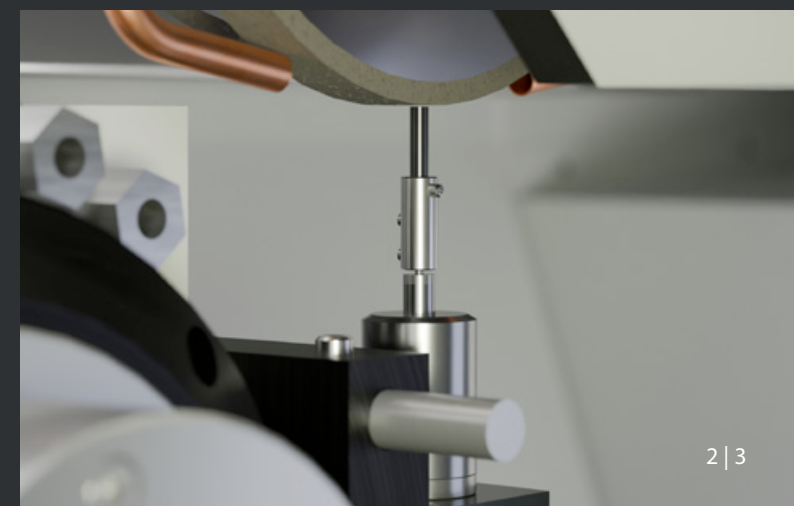
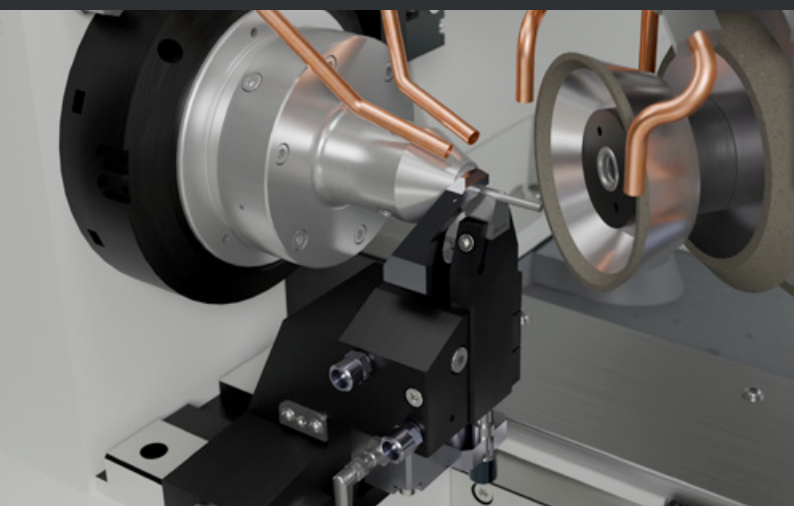

WZS 8 REINECKER

Automatic Wheel Changer

- Magazine for 8 grinding wheel packages separated from the work area.
- Automatic changeover of wheel package and coolant manifold in one unit is optional.
- Dimensions of the wheel packages:
Diameter → max. 150 mm [5.9"]
Total length → max. 150 mm [5.9"]

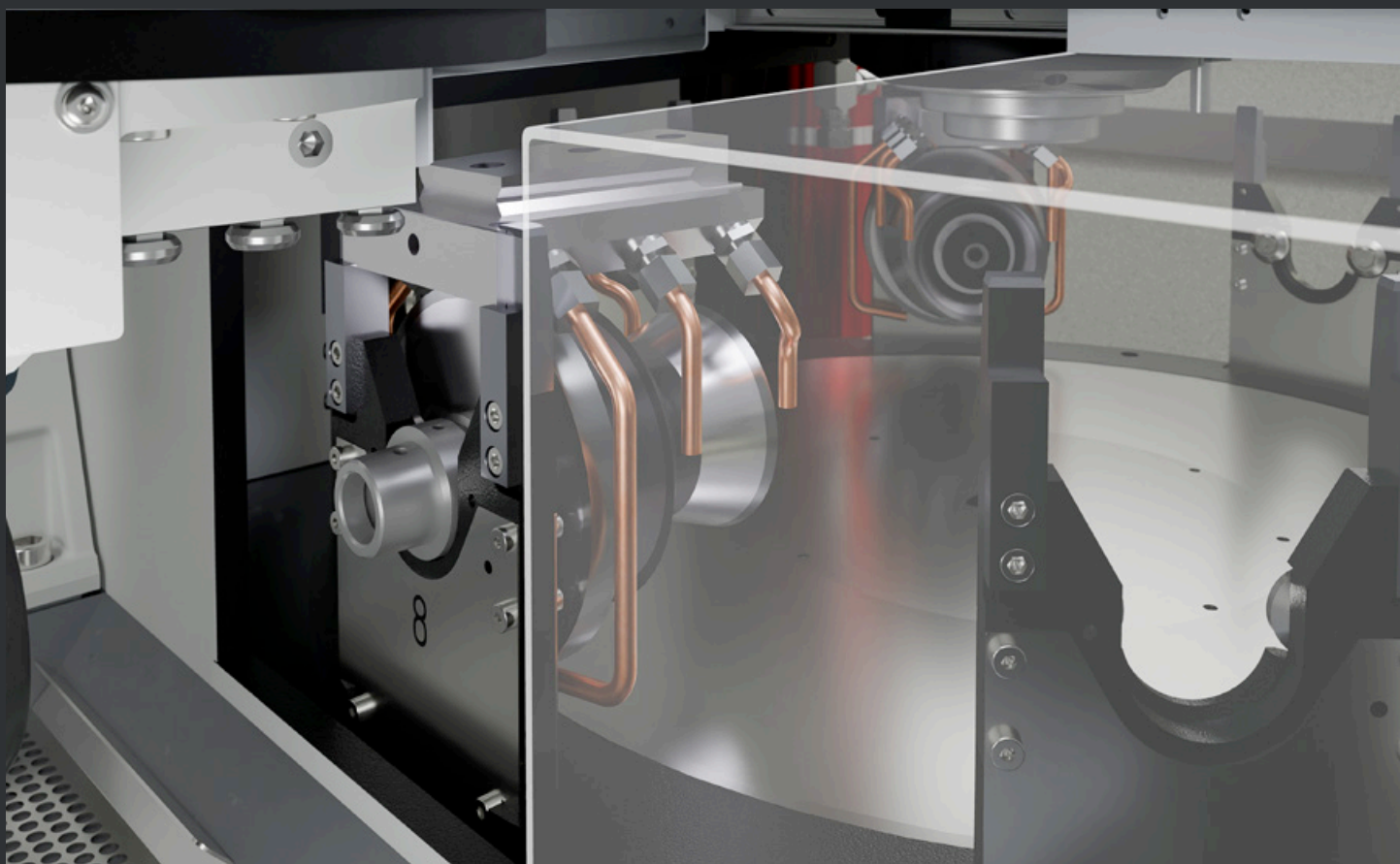

Automation Solutions



Pick-up automation with chain magazine

Automatic loading of workpieces with different shank diameters. For small batch sizes and individual parts.

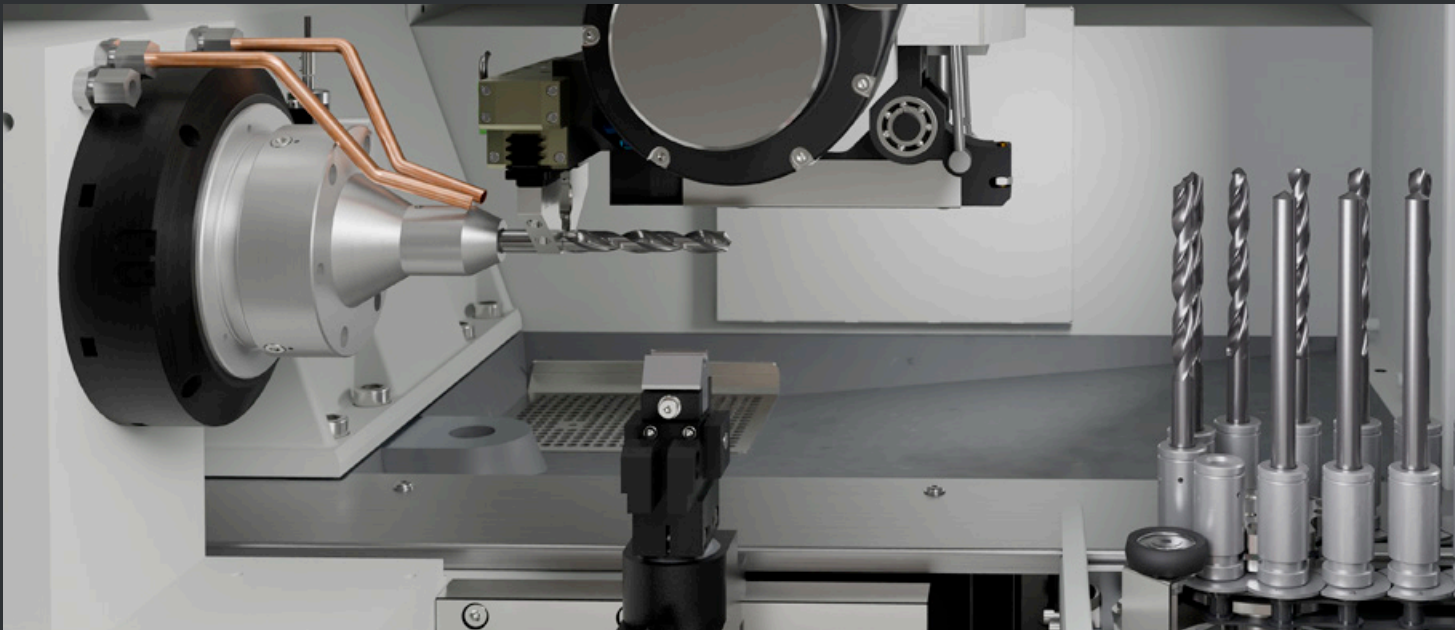

Possible shank diameters:

Gripper set 1 → D = 2 - 20 mm [0.08 - 0.79"]

Gripper set 2 → D = 14 - 32 mm [0.55 - 1.26"]

Workpiece length → max. 150 mm [5.9"]

Separated Chain Magazine Compartment

Quality control at any time during processing (parallel to machining).

Workpiece capacity → max. 128 parts

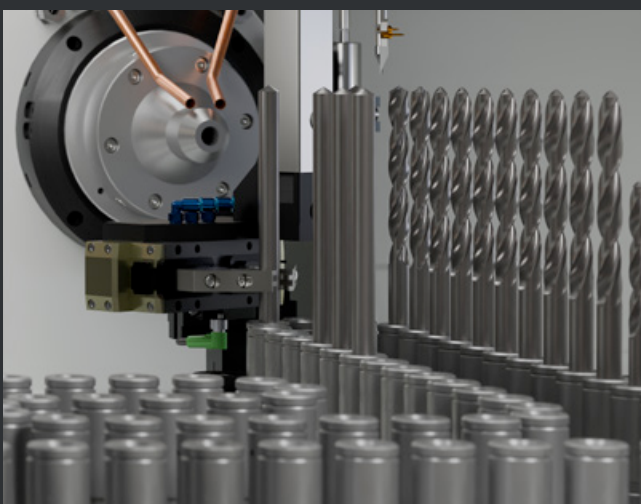

WZS 8 REINECKER Automation Solutions



Robot automation

High capacity and fast changeover times guarantee optimum processing of medium batch sizes.

Parallel double gripper

Diameter ranges:

Gripper set 1 → D = 0 - 10 mm [0 - 0.39"]

Gripper set 2 → D = 3 - 15 mm [0.12 - 0.59"]

Gripper set 3 → D = 15 - 25 mm [0.59 - 0.98"]

Gripper set 4 → D = 25 - 32 mm [0.98 - 1.26"]

Loading device with up to 4 pallets

Example of workpiece capacity:

Shank diameter 6 mm [0.24"] → 792 parts

Shank diameter 10 mm [0.39"] → 450 parts

Workpiece length → max. 250 mm [9.84"]

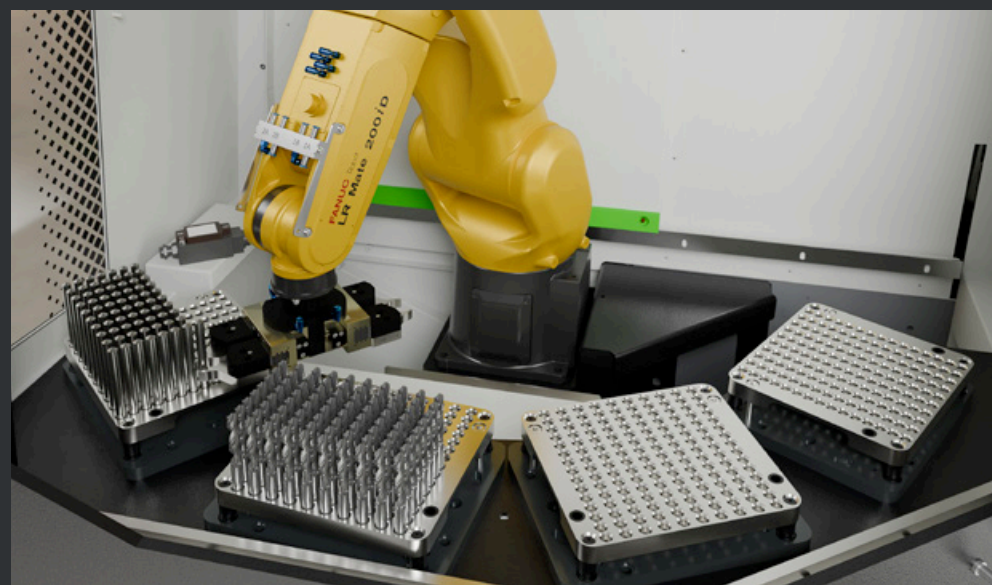



Pick-up automation with 2 pallets

Simple set-up and reliable changing of workpieces, even in hydraulic chucks. Various workpiece pallets can be adapted.

Possible shank diameter:

Gripper set → D = 2 - 20 mm [0.08 - 0.79"]



Separated Pallet Compartment

Quality control at any time during processing (parallel to machining).

Workpiece capacity (example):

Shank diameter 6 mm [0.24"] → 264 parts

Shank diameter 10 mm [0.39"] → 150 parts

Workpiece length → max. 150 mm [5.9"]

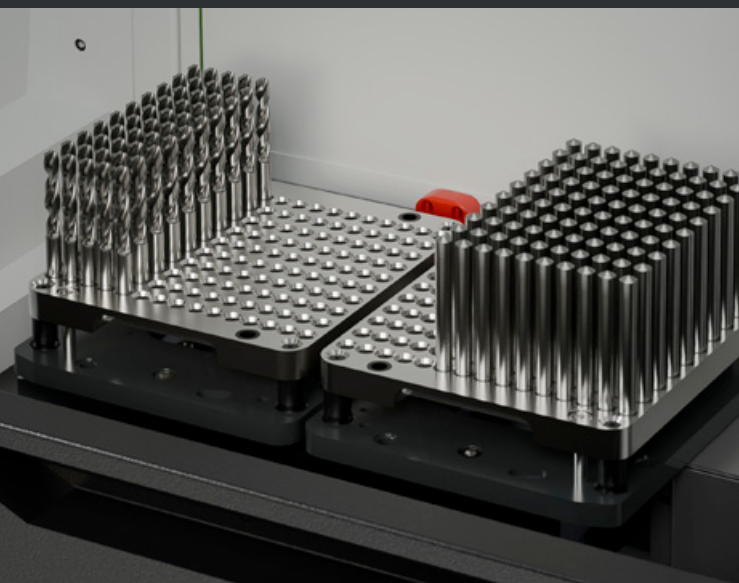

WZS 8 REINECKER

Technical Details

EN 10 | 25

Performance data WZS 8

Travels of axes	X-axis	750 mm [29.5"]
	Y-axis	250 mm [9.8"]
	Z-axis	600 mm [23.6"]
	B-axis	+20° / -200°
	C-axis	n x 360°
Resolution	X, Y, Z-axis	0.0001 mm
	B, C-axis	0.0001°
Axis drives	X, Z-axis (direct drive)	2.3 kN
	Y-axis (KGT)	5 kN
	B-axis	350 Nm
	Rapid travel speed X / Y / Z	30 / 15 / 30 m/min
Grinding spindle	Motor spindle Rated power	Ø 144 x 347 mm [5.67 x 13.66"]
	Nominal power	10 kW [14 hp]
	Peak power	16 kW [21 hp]
	Speed infinitely variable (option)	up to 9,000 (12,000) rpm
	Torque const.	12 Nm up to 9,000 rpm
	Grinding wheels Ø max.	150 mm [5.9"]
	Internal taper	HSK 50E
Workpiece spindle	Internal taper	ISO-50
	Speed max.	2,000 rpm
	Torque max.	60 Nm
Machine	Total connected load	15 kVA
	Supply voltage / Frequency	400 V / 50 Hz
	Machine (basic) W x D x H	2,070 x 2,210 x 2,440 mm [81.5 x 87.0 x 96.1"]
	with robot att. W x D x H	2,430 x 2,210 x 2,440 mm [95.7 x 87.0 x 96.1"]
	Weight	approx. 5 t [11,023 lbs.]

Kinematics

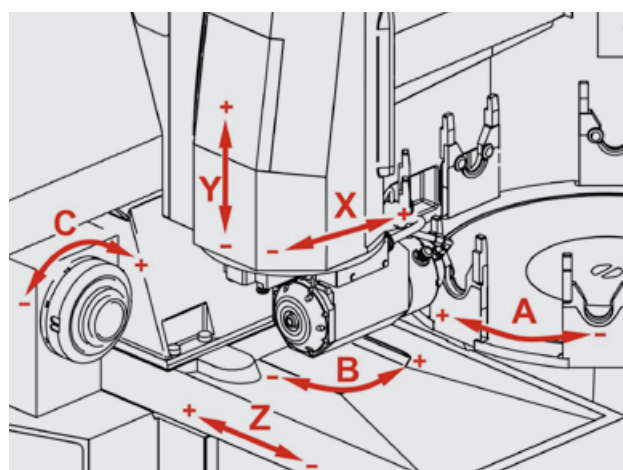

Dimensions in mm [inch]

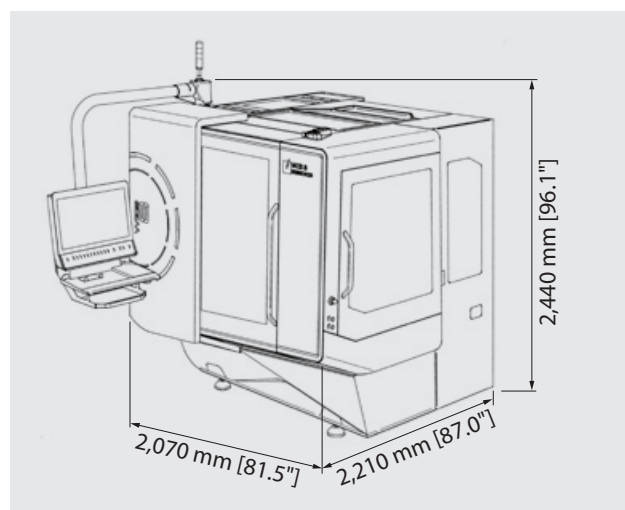

Workpiece dimensions (Dimensions from taper zero line ISO 50)

Manual loading	Ø max.	200 mm [7.9"]
	Length max.	250 mm [9.8"]
	Weight max.	20 kg [44 lbs.]
Automatic loading	Ø max.	32 mm [1.26"]
	Length max.	150 / 250 mm [5.9 / 9.8"]
	Weight max.	2.5 kg [5.5 lbs.]

Ulmer Werkzeugschleiftechnik GmbH & Co.KG

August-Nagel-Str. 9
89079 Ulm-Einsingen, Germany
Tel. +49(0)7305/171-324
Fax +49(0)7305/171-328
info@werkzeugschleifen.de
www.werkzeugschleifen.de



REINECKER