

## VERTICAL BANDFACERS

### ANTELOPE - AN Series , Dust Extraction Mounted

The RJH Morrisflex ANTELOPE Bandfacer is one of our most popular machines. It has been designed to meet strict performance and safety criteria, and is therefore ideal for use in schools and colleges as well as in industry. These machines are suitable for working on wood, acrylic or metal. The ANTELOPE fully complies with UK COSHH regulations, the European Machinery Directive and also with the BS4163 "Health & Safety in Workshops of Schools and Similar Establishments" regulations. All RJH Morrisflex machines carry a 24 month warranty and are supplied with a comprehensive operating manual.

#### KEY FEATURES

- Integral dust extractor with a tray collector for easier and cleaner waste handling
- Quick action calibrated tilting table for operating positions between 90 and 135 degrees
- Adjustable protractor guide
- Thumb screws for belt adjustment
- Supplied with 150 x 1090 mm aluminium oxide abrasive belt

#### SAFETY FEATURES

- No-volt overload push-button starter
- 110 volt control circuit
- Knee stop bar
- Fire retardant terylene needlefelt dustbag
- Full guarding including adjustable front belt guard for maximum finger protection
- Protective motor cover

#### OPTIONAL REFINEMENTS

- Flexible halogen floodlight with transformer
- Lockable triple pole isolator
- Single phase unit
- Lockable "E" Stop



**Antelope, AN1503VCOB**



Electric Controls



Work Table & Protractor



Knee Stop Bar



Thumb screw for the adjustment of belt

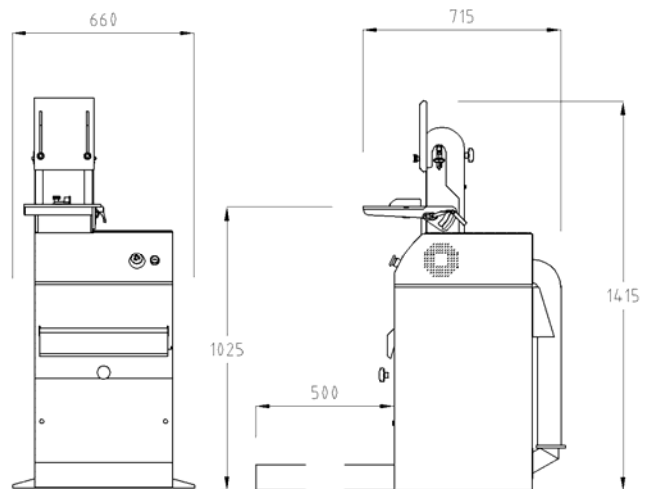

Front

Side





*Further information and full specifications from:*

**RJH MORRISFLEX LTD**, Artillery Street, Heckmondwike, West Yorkshire, WF16 0NR, United Kingdom  
 Tel: 01924 402490 International: (0044) 1924 402490 Fax: 01924 404635 International: (0044) 1924 404635  
 Email us on [sales@rjheng.co.uk](mailto:sales@rjheng.co.uk), or visit us @ [www.rjheng.co.uk](http://www.rjheng.co.uk)

## VERTICAL BANDFACERS

### DEER - AN Series, Bench and Pedestal Mounted

The RJK Morrisflex DEER is a bench or pedestal bandfacer designed for use with centralised dust extraction systems. The DEER incorporates the same safety features as the ANTELOPE workhead, and is available with the same optional refinements. The differences to the ANTELOPE are detailed in the table below:

KEY: ● =included, ✕ =not available	ANTELOPE	DEER - PEDESTAL	DEER - BENCH
Dust Extractor	●	✕	✕
Push-button Stop 	●	●	●
Knee Stop Bar 	●	✕	✕
Foot Stop 	✕	●	✕
110V control system 	●	●	●



**Deer, AN150V3P**

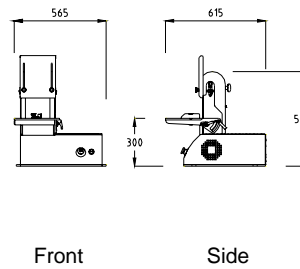
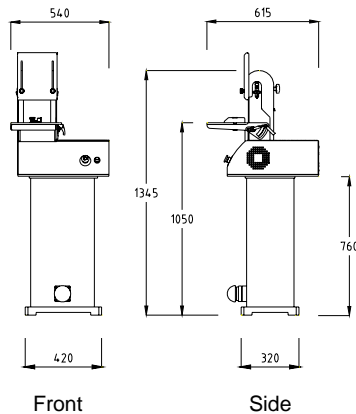

**Deer, AN150V3B**

### SPECIFICATION - ANTELOPE & DEER Bandfacers

MODEL	ANTELOPE - DUST EXTRACTION	DEER - PEDESTAL	DEER - BENCH
3 phase	AN150V3COB	AN150V3P	AN150V3B
1 phase	AN150V1COB	AN150V1P	AN150V1B
Weight	135 Kg	97 Kg	77 Kg
Dust Extractor Motor	0.55 Kw	N/A	N/A
Electrical Supply	3 phase = 400/3/50, 1 phase = 230/1/50		
Belt Drive Motor	3 phase = 1.5 Kw, 1 phase = 0.75 Kw		
Belt Size	150 x 1090 mm		
Belt Speed	6.5 m/sec		
Spindle Speed	1500 rpm		
Work Table Size	278 (w) x 226 (d) mm		

*Further information and full specifications from:*

RJK MORRISFLEX LTD, Artillery Street, Heckmondwike, West Yorkshire, WF16 0NR, United Kingdom  
 Tel: 01924 402490 International: (0044) 1924 402490 Fax: 01924 404635 International: (0044) 1924 404635  
 Email us on [sales@rjheng.co.uk](mailto:sales@rjheng.co.uk), or visit us @ [www.rjheng.co.uk](http://www.rjheng.co.uk)